

SynJet[®] Power Supply Connections & ON-OFF Sequence

Overview

IMPORTANT: SynJet Coolers should be completely wired to the power supply before the power supply is energized. The power supply should be turned off before the SynJet Cooler is disconnected. Failure to do so could result in damage to the SynJet Cooler's internal circuitry. SynJet Coolers are not designed for "hot swap" or "hot plug" applications.

This app note outlines the recommended procedure for connection of the SynJet Cooler to its power source. This includes the sequence for making connections, turning on the Power Supply after the SynJet Cooler is connected, and turning off the Power Supply before the SynJet Cooler is disconnected.

The recommendation, as noted above, is to first make all power wiring connections to the SynJet Cooler, and then turn on the power supply. Similarly, turn off the power supply before disconnecting the SynJet power connection.

Do NOT "HOT Plug or Unplug" the SynJet Cooler power.

Details

The reason for this sequence is to avoid the possibility of a short term (fraction of a second) connection from the +V, Pin 1 (Red Wire), through the electronics, to either of the control signal inputs, Pin 3 (Purple Wire) or Pin 4 (Blue Wire) BEFORE the normal return current path is connected through Pin 2 (Black Wire). As the connector is pushed on to make connections or removed to break connections, the four Pins do not make/break simultaneously, there is always a small difference in the time. This "small time difference", establishes a possible short term sneak current path, e.g., from +V, Pin 1, through the SynJet electronics to Pin 4, effectively becoming GND, instead of Pin 2. Net, the SynJet electronics is designed to operate with normal connections and current flow. Abnormal connections, even for a short time, may cause failures or weaken an internal component and create a reliability problem.

Example: Power Wiring and PWM Cooling Level Selection

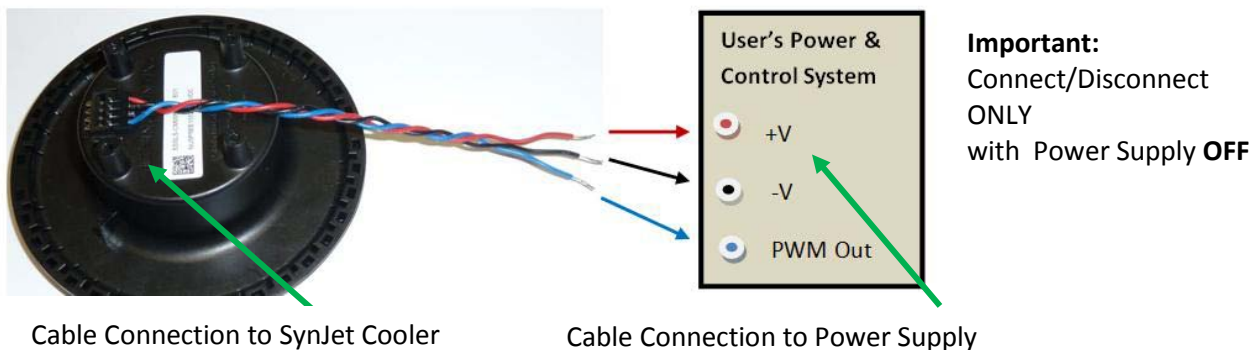

APPLICATION NOTE

Additional “Power Pitfalls” – Items to Check BEFORE applying Power.

1. Verify the SynJet Cooler voltage input is matched to the Power Supply. Check Label.

Connect 12V SynJet to only a 12V Constant Voltage Power Supply

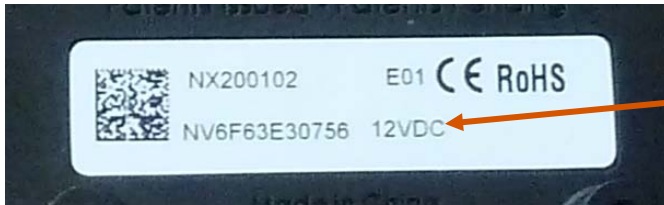

12V
SynJet Cooler &
Power Supply

Connect 5V SynJet to only a 5V Constant Voltage Power Supply



5V
SynJet Cooler &
Power Supply

(Continued on Next Page)

APPLICATION NOTE

2. Verify Power Supply Output Voltage & Wiring (+V & -V) for SynJet Power.

DO NOT rely on Wire Colors only. Do not simply connect Red to Red and Black to Black without verification.

Example 1: LED Driver may have several wiring connections, such as: LED Drive Constant Current (+ Red & - Black); 0-10V Dimmer connection (+ Yellow & - Brown); NTC Thermal Sensor (+ Blue & - Gray); SynJet Output Voltage Tap (+V Orange & -V White). In this configuration, verify the correct voltage and polarity with a meter, then, connect the Orange Wire to the SynJet Red Wire & the White Wire to the SynJet Black Wire.

Example 2: Some Power Supplies do not follow a common convention of using a Black wire for -V. Instead, the +V output may be on the Black Wire. In this case, connecting “Black to Black” will reverse the polarity of the power into the SynJet, and cause a failure immediately.

Example 3: The Multiple Output LED Driver described above has four “-” terminal connections. Usually, these are NOT the same point electrically. Wire the SynJet Black Wire only to the LED Driver or Power Supply terminal designated for “-V” SynJet. DO NOT join it with any other wire or terminal.

(Continued on Next Page)

APPLICATION NOTE

- 3. LEDs are typically driven using a Constant Current Power Source. The SynJet Cooler requires a Constant Voltage Power Source.** Connecting the SynJet to a constant current power source or in parallel with the LED Array is likely to cause an overvoltage, thus cause the SynJet to fail.
- 4. SynJet Coolers are available in two models for user cooling level selection, PWM/CVC and Level Select.** Refer to the Product Specification to verify the model type. Verify wiring for Pin 3 (Purple Wire) and Pin 4 (Blue Wire) to be sure the wires are connected properly to give the desired cooling.

Example:

For SynJet with Level Select Cooling, attach Blue Wire to Black Wire (GND) to select High Performance Cooling.

For SynJet with PWM Cooling, leave Blue Wire open (maximum cooling similar to High Performance) or attach to User's control signal source for intermediate cooling.

"Pitfall" – If the cooler is PWM and the Blue Wire is attached to GND (Black Wire), this selects "0%" cooling, i.e., no air flow is felt, no acoustics, and minimal power from the power supply, SynJet appears to be not working. Remove the Blue wire connection from GND, to return to normal operation. This does not damage the SynJet Cooler.

Recommendation – Verify all wiring connections with the Product Specification data sheet; refer to: www.nuventix.com