

SynJet® Cooling Pulse Width Modulation (PWM) or Control Voltage Cooling (CVC)

Overview

This App Note gives an overview of SynJet user variable cooling control. PWM operation is described along with interface design requirements for using a Pulse Width Modulation (PWM) signal to control the performance level of a SynJet cooler. Control Voltage Cooling (CVC) operation, “analog control” is also described along with interface design requirements for using a variable analog voltage level input signal to adjust the performance level of a SynJet cooler. It also covers the electrical specifications for power and control signals and the connector and cable wiring information for these signals.

These control options allow users to adjust the performance of the cooler dynamically to meet specific cooling, power and acoustic requirements. The same SynJet Cooler part number accepts either type of control input. No additional user selection needed.

Users requiring permanent maximum cooling, leave Pin 4 open, Blue Wire removed or not connected.

Details

Features/Benefits

- Lower overall power consumption for the life of the product
- Dynamically match cooling to actual environment requirements
- Allows user to stock one cooler and match it to the range of cooling, acoustic, and power requirements of multiple designs

(Continued on Next Page)

APPLICATION NOTE

Control Operation

The relationship for cooling level versus user input control signal is shown in Figure 1. As the PWM Duty Cycle or analog Control Voltage increases, the Active Cooling Level increases. The horizontal axis shows the relationship for either option (PWM or CVC).

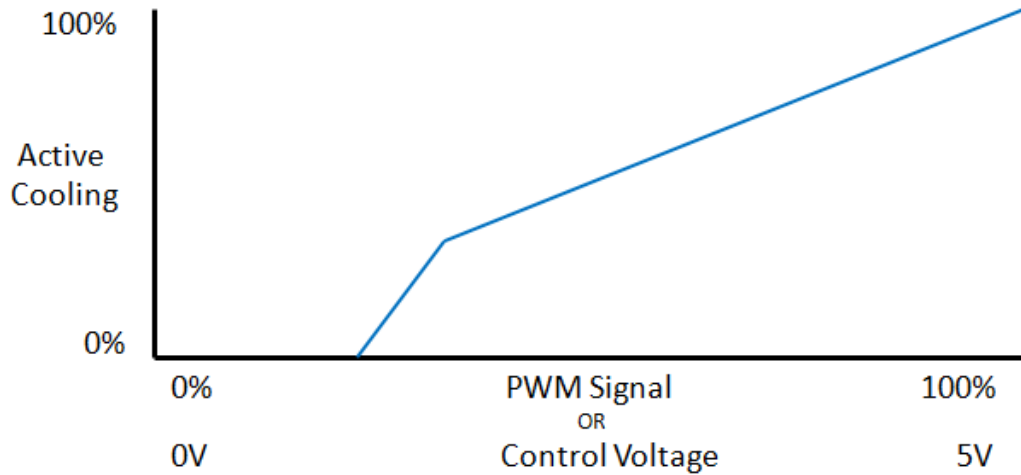

Figure 1. SynJet Active Cooling versus User Input Signal

Pulse Width Modulation (PWM) Operation

The PWM control signal is a square wave with a variable Duty Cycle (% of "on" time). An Example is shown in Figure 2.

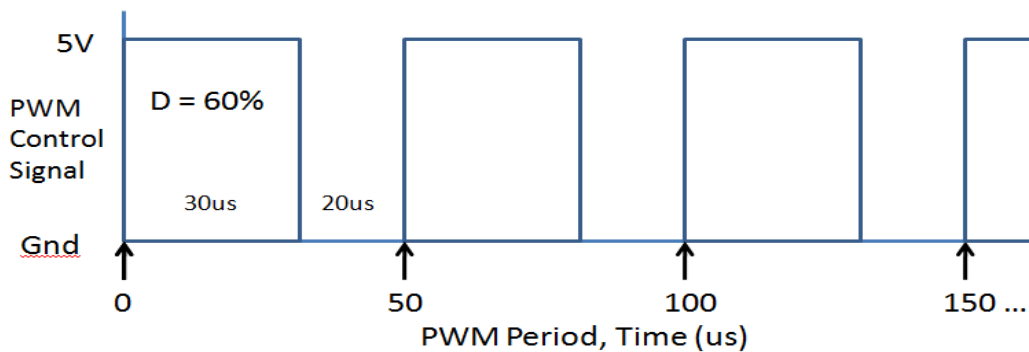

Figure 2. PWM Control Signal - User System to SynJet Pin 4 (Blue Wire)

Example: Refer to Figure 2. 20KHz PWM signal, Period = 50us, 60% Cooling (Duty Cycle) = 5V for 30us & GND for 20us, this cycle repeats. The SynJet electronics averages this signal for the cooling level.

The PWM signal is received at the SynJet pin CTL1 (Connector Pin 4, Blue Wire) and internally converted into an analog DC control voltage level which is used to scale the cooling performance (actuator)

APPLICATION NOTE

displacement) of the SynJet. With a 100% PWM duty cycle the SynJet will operate at the maximum cooling performance. Cooling performance is scaled approximately linearly between 25% and 100%. Below 25% the SynJet provides minimal cooling, and consumes little power. The PWM driver should be an open-drain / open-collector topology which allows the internal pull-up resistor in the SynJet controller to set the voltage for the positive portion of the duty cycle.

IMPORTANT:

1. The SynJet Connector Pin 4, Blue Wire, is a control signal input. It is NOT a power input. Some PWM controllers used to drive fans use the same wire for power and control, i.e., the +V is switched on/off at the PWM Duty Cycle. The +V for the SynJet (Pin 1, Red Wire) must be from a constant voltage power supply, 5V or 12V, depending upon the SynJet Cooler model.
2. Some dimmable LED drivers use PWM constant current modulation to dim the LEDs. Pin 4, Blue Wire, should NOT be connected directly across the LED driver output. LED driver voltages are typically much greater than the 5V max allowed, and/or the return wire may not be at the same potential as the SynJet Pin 2 (Black Wire) GND. Excessive electrical noise may also be coupled into the SynJet. If the timing from the PWM is used, it should be buffered, filtered and level adjusted before driving Pin 4, Blue Wire (See Table 1).

For permanent maximum cooling, leave Pin 4 open, Blue Wire removed or not connected. The SynJet will default to maximum cooling performance.

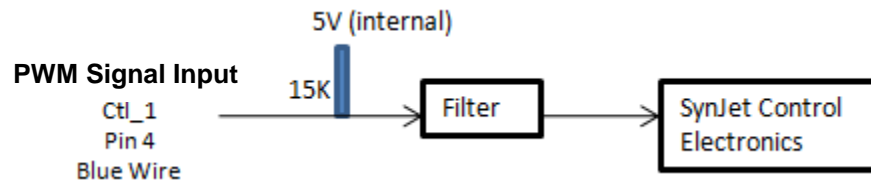

(Continued on Next Page)

APPLICATION NOTE

Control Voltage Cooling (CVC) Operation

The relationship for cooling is shown in Figure 1, as the Control Voltage increases, the Active Cooling Level increases. The analog control signal is a 0V to 5V DC voltage approximately proportional to the Active Cooling % required. Below 1.5v, the SynJet provides minimal cooling, and consumes little power.

For permanent maximum cooling, leave Pin 4 open, Blue Wire removed or not connected. The SynJet will default to maximum cooling performance.

Cooling Level Control – Block Diagram of Circuit Elements

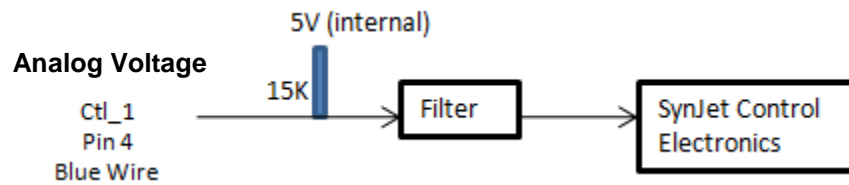

Figure 4. SynJet “Analog Voltage” Control Input Circuit

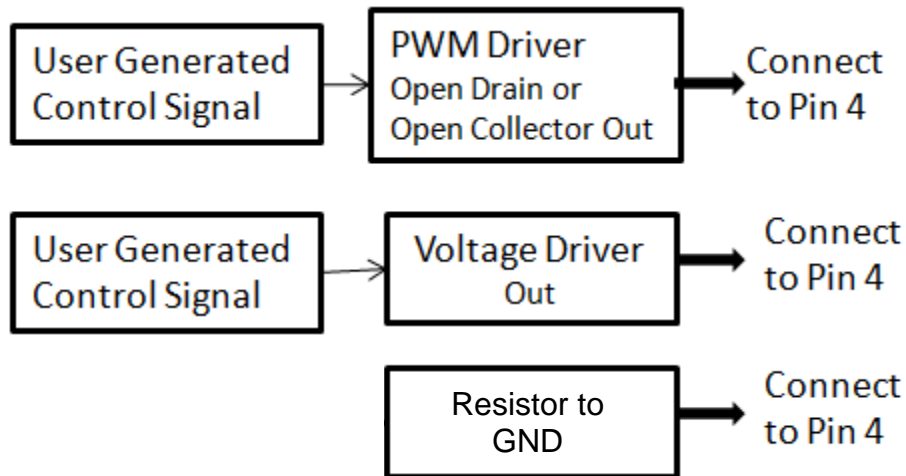

Figure 5. User Control Signal Output – Typical User Circuits

(Continued on Next Page)

APPLICATION NOTE

WALLS 4 Wire Cable – For “PWM 100%” Fixed Level Selection,

User removes Blue Wire & Purple Wire

Note: PWM 100% Fixed gives maximum cooling, similar to Level Select “High Performance” cooling.

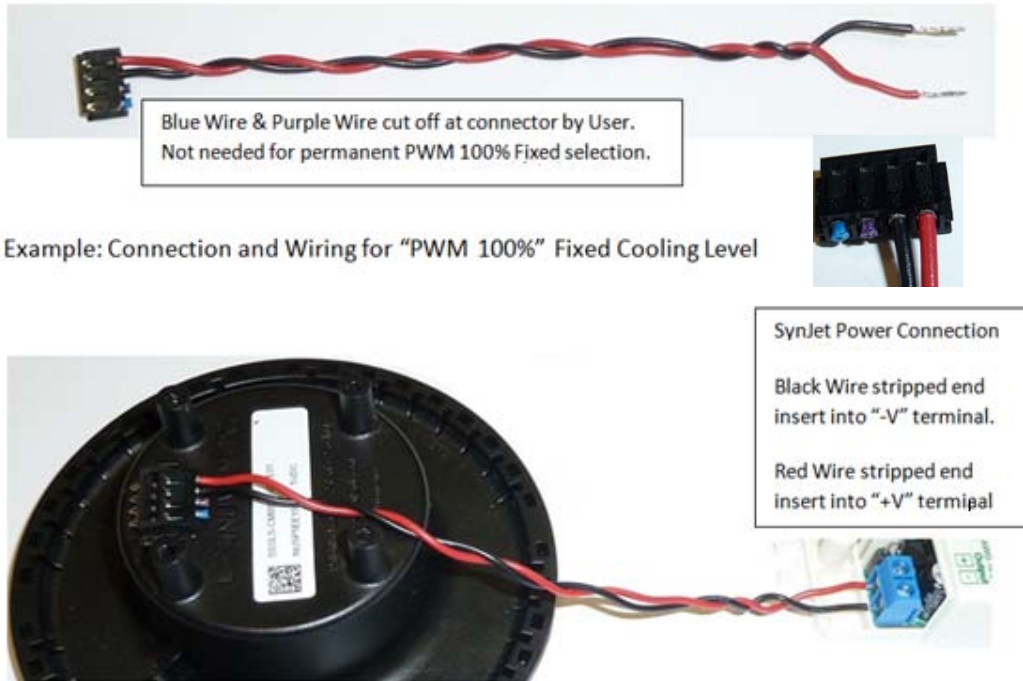

Figure 3. Permanent PWM 100% or CVC Maximum Cooling Level Selection

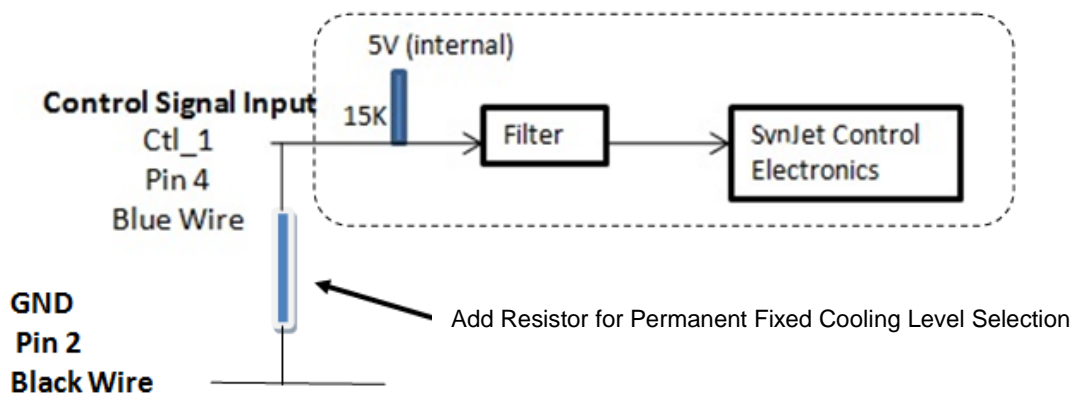

Figure 6. Block Diagram – Fixed Resistor and Pin 4 Connection

As shown in Figure 6, the User may permanently set the cooling level to an intermediate value by adding a resistor to GND. The User can determine the desired cooling by evaluating several resistance values.

APPLICATION NOTE

If the same R value is used for a large lot of SynJet Coolers, the User should expect a moderate variation in cooling level (typically +/-15%) due to normal manufacturing materials differences.

Electrical Specifications

PWM or CVC control signals are connected to the CTL1 input (Connector Pin 4). For PWM, this pin is intended to be driven by an open-drain or open-collector output on the user's side and has an internal pull-up connected to 5Vdc (on 12V models the 5V is generated internally on the SynJet controller). The PWM signal polarity is not inverted. This means a 100% duty cycle will correspond to 5V DC (due to pull-up resistor in the SynJet electronics) as measured at the CTL1 input (Pin 4) of the SynJet. Figure 2 shows details of the PWM signal.

For CVC, this pin can be driven with a voltage divider, DAC or other circuit that can generate an analog voltage. **The recommended circuit for applications that require a static setting is a voltage divider that uses the internal 15k pull-up and an external resistor between CTL1 and GND.** This circuit requires the minimum components and ensures that the control voltage is not applied before Vcc. **IMPORTANT** - If the user uses a different circuit it must be designed so that the control voltage is applied after Vcc comes up and that the control voltage does not exceed the rating in Table 2. Refer to Tables 1, 2, and 3 for absolute max operating conditions of the CTL1 pin and recommended operating conditions.

Table 1 - Absolute Maximum Ratings

Over operating free-air temperature range unless otherwise noted⁽¹⁾

	MIN	MAX	UNIT
Voltage at CTL1	-0.3	5.3	V

- (1) Stresses beyond those listed under "absolute maximum ratings" may cause permanent damage to the device. These are stress ratings only, and functional operation of the device at these or any other conditions beyond those indicated under "recommended operating conditions" is not implied. Exposure to absolute-maximum-rated conditions for extended periods may affect device reliability.

(Continued on Next Page)

APPLICATION NOTE

Table 2 - Recommended Operating Conditions

	MIN	MAX	UNIT
Voltage at CTL1 (5 V or 12V cooler) ⁽⁴⁾	0	5.0	V
PWM frequency	20	40	kHz
PWM duty cycle	0	100	%
Capacitive loading on CTL1 pin ⁽²⁾		40	pF
User PWM driver output resistance ⁽³⁾		200	Ω

- (2) Additional capacitive loading will reduce the rise-time of the PWM signal due to the resistance of the internal pull-up. The SynJet will continue to function but the maximum cooling level will be slightly reduced. Higher PWM frequencies will be more susceptible to this effect because the rise time represents a greater percentage of the total PWM period.
- (3) Drivers with higher output resistance may be used but the minimum cooling level that can be achieved may be reduced.
- (4) **IMPORTANT** - This Input must NOT exceed 5v, even for 12V models. Do Not use a pull-up resistor to 12V.

Table 3 - Electrical Characteristics

	Test Conditions	MIN	TYP	MAX	UNIT
I_{L-CTL1}	$V_{CTL1} = 0V$			530	μA
I_{H-CTL1}	$V_{CTL1} = 5V$			1	μA
CTL1 Internal Pull-up Resistor ($R_{pull-up}$)		10.5	15	19.5	k Ω

(Continued on Next Page)

APPLICATION NOTE

SynJet 4 Wire Cable and Connector Information

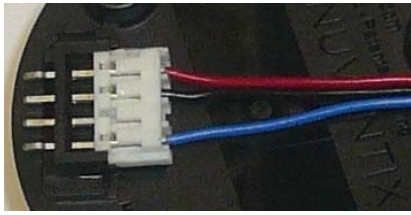

Power and PWM or CVC

Pin 1	RED	Power (5V or 12V)
Pin 2	Black	GND
Pin 3	N/C	See Note below
Pin 4	Blue	CTL 1 (PWM or CVC)

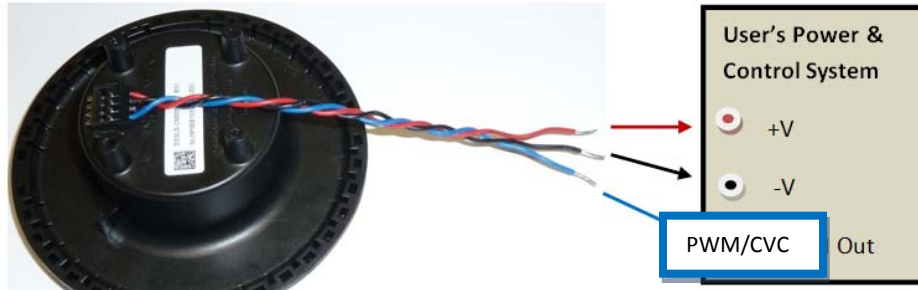

Figure 10. SynJet Power and Control Electrical Interface to User System

Note: Pin 3, Purple Wire, SynJet Heartbeat (Status) Output.

Use of this signal is not necessary for the PWM or CVC cooling control applications. User may remove this wire, cut off at connector as shown in Figure 3, or leave it not connected but with the stripped end covered to prevent an accidental short to a conductive surface.

Refer to Application Note: "SynJet® Cooler Heartbeat (Status) Signal Output Interface Specification" for details.

(Continued on Next Page)

APPLICATION NOTE

SynJet - Connector and Wire Details	
4 Pin Connector Molded into Housing	Manufacturer: JST Part Number: S4B-EH
Mating 4 Pin Connector on End of Cable	Manufacturer: JST Part Number: EHR-4
Wire	24AWG, stranded, Insulation O.D. is 1.9mm
Wire: UL Recognized	Category 7ZPFW2 or VZQC2



Connector Detail: Pin Numbers are molded into the cable connector

Comments and Suggestions

- 1. IMPORTANT** - Connect SynJet to Power Source: Make the Black Wire (-V) connection first, & the Red Wire (+V) last. Disconnect in reverse order, the Red Wire (+V) first.
- 2. Refer to Product Specification Sheet and Technical Design Guide for additional details.**
- Depending upon the attachment mechanism at the Power Source terminal, the User may want to “tin” the ends of the stranded & stripped wires for easier insertion/attachment.
- If building a custom cable, the User can insert only the needed wires, i.e., 2 or 3 or 4 wires, into the connector, instead of adding wire and cutting it off. The connector has a locking mechanism to hold it in place independent of contact friction.
- The crimped pins lock into place when inserted into the black connector. Individual pins can be carefully removed from the connector, if desired, instead of cutting the wire off at the edge where it emerges from the connector.
- Note – Early production of this cable used a white connector. Present production uses the same connector in black color. Both colors are the same form-fit-function.